



CÓDIGO: 45059 CLAVE: R-502S

Regadera redonda metálica 3" sin brazo, Foset

- Ahorradora en baja presión
- Cabeza metálica
- Para mayor flujo de agua se puede retirar el reductor



Grado ecológico

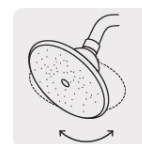

Articulada

Certificaciones y garantías

- Cumple la norma NOM-008-CONAGUA



Especificaciones

Diámetro de la cabeza	3" (8 cm)
Acabado	Cromo
Presión de trabajo	0.25 kgf/cm ² a 6 kgf/cm ²
Conexión roscable	1/2" - 14 NPT
Peso	155 g
Empaque individual	Bolsa
Inner	2
Master	24
Pallet	1248

Datos de Empaque (Medidas y pesos aproximados)

Empaque Individual	Medidas: Alto: 18 cm (7") Ancho: 7.8 cm (3") Largo: 12 cm (4 3/4") Peso: 0.16 kg (0.35 lb)
Inner	Medidas: Alto: 7.5 cm (3") Ancho: 12.5 cm (5") Largo: 16 cm (6 1/4") Peso: 0.36 kg (0.79 lb)

Datos de Empaque (Medidas y pesos aproximados)

Master

Medidas: Alto: 25 cm (9 3/4") Ancho: 27.5 cm (10 3/4") Largo: 33.5 cm (13 1/4") **Peso:** 4.78 kg (10.54 lb)

País de origen

Fabricado en China bajo las estrictas especificaciones de GRUPO TRUPER

Imágenes complementarias

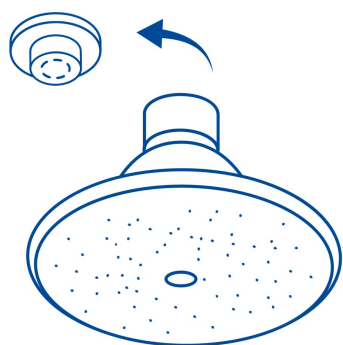
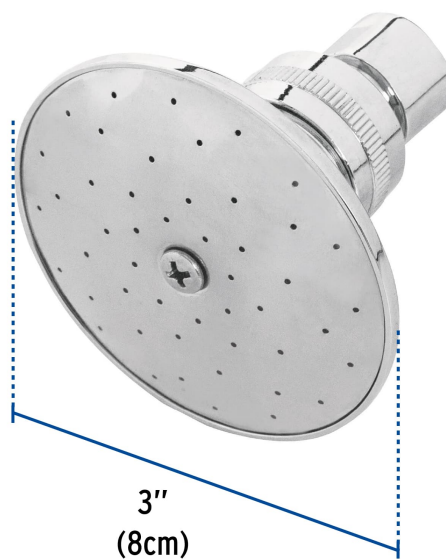
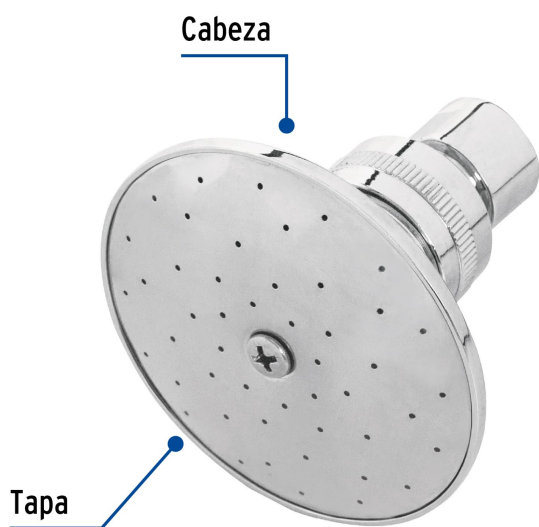

Altura (h)	Presión		
	kPa	kg/cm ²	PSI
2 m	20	0.2	2.8
3 m	30	0.3	4.2
4 m	40	0.4	5.6

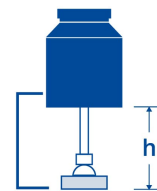

Para mayor flujo de agua se puede retirar el reductor

Imagenes complementarias

Para regadera redonda con acabado cromo



R-502

EMPAQUE INDIVIDUAL



Peso: 0.2 kg (0.4 lb)



EMPAQUE INNER



Contiene: 2 piezas

Peso: 0.4 kg (0.8 lb)

Imágenes complementarias

EMPAQUE MASTER



Contiene: 12 inner (24 piezas)

Peso: 4.8 kg (10.5 lb)