

CÓDIGO: 48467 CLAVE: GUPO-201

## Cinta guardapolvo 1 m x 35 mm, transparente, HERMEX

- Flexible, se adapta a curvas y ángulos
- Puede cortarse para ajustar al tamaño deseado
- Adhesivo de alta resistencia
- Evita la entrada de polvo, aire e insectos
- Ideal para puertas y ventanas



### Certificaciones y garantías



### Especificaciones

Dimensiones (largo x ancho)	1 m x 3.5 cm
Ancho (con adhesivo x sin adhesivo)	1.5 x 2 cm
Espesor	0.6 mm
Inner	6
Master	48
Pallet	2880

### País de origen

Fabricado en China bajo las estrictas especificaciones de GRUPO TRUPER

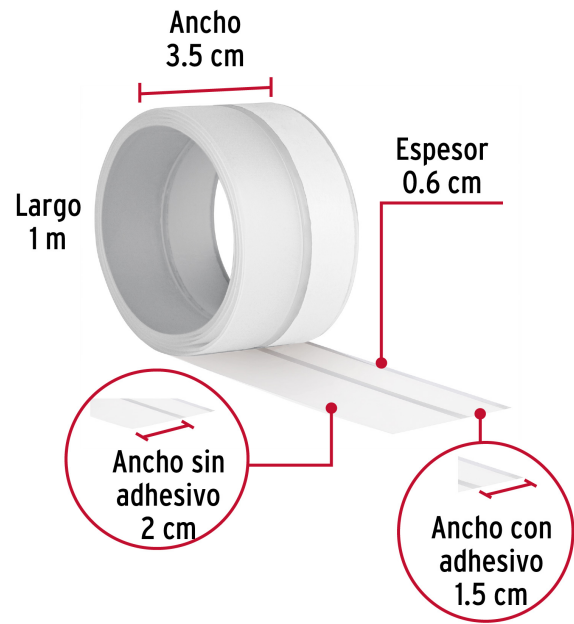
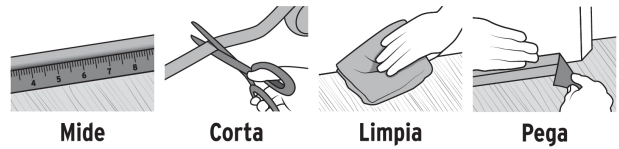
**Imágenes complementarias****Fácil instalación**

Imágenes complementarias



Antes



Después

