

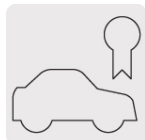



CÓDIGO: 44248 CLAVE: AB-60

Bolsa c/5 abrazaderas sin fin reforzadas #60, 3-5/16-4-1/4"

- Banda de acero inoxidable
- Tornillo de acero
- Para uso automotriz, industrial y doméstico



Calidad automotriz



Uso industrial



Uso doméstico

Certificaciones y garantías

- Excede la norma: ANSI / SAE: J1508
- Garantizado contra defectos de fabricación o mano de obra. La garantía se puede hacer válida con cualquier distribuidor de TRUPER

Especificaciones

Diámetro mínimo	3-5/16" (84 mm)
Diámetro máximo	4-1/4" (105 mm)
Ancho	1/2" (13 mm)
Empaque individual	Bolsa con 5 piezas
Pallet	1040
Inner	4
Master	16

Datos de Empaque (Medidas y pesos aproximados)

Empaque Individual	Medidas: Alto: 22 cm (8 3/4") Ancho: 5 cm (2") Largo: 17.5 cm (7") Peso: 0.19 kg (0.42 lb)
Inner	Medidas: Alto: 19.8 cm (7 3/4") Ancho: 12.6 cm (5") Largo: 18.1 cm (7 1/4") Peso: 0.86 kg (1.90 lb)
Master	Medidas: Alto: 21 cm (8 1/4") Ancho: 26.2 cm (10 1/4") Largo: 37.5 cm (14 3/4") Peso: 3.84 kg (8.47 lb)

País de origen

Fabricado en China bajo las estrictas especificaciones de GRUPO TRUPER

Imágenes complementarias

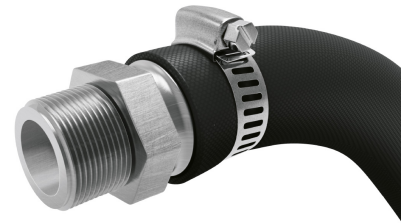
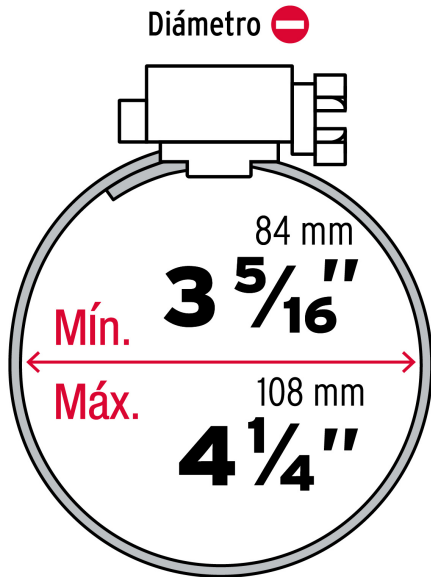

Imágenes complementarias



EMPAQUE INDIVIDUAL



EMPAQUE INNER



Contiene: 4 piezas

Peso: 0.86 kg (1.90 lb)

EMPAQUE MASTER

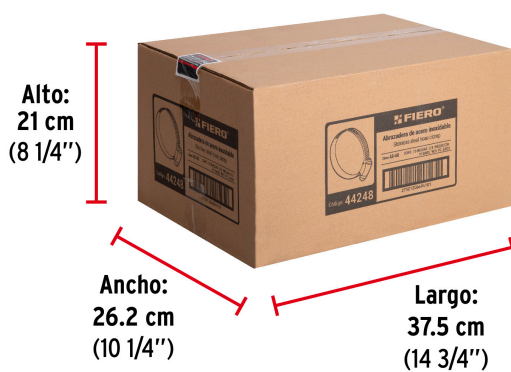

Contiene: 4 inner (16 piezas)

Peso: 3.84 kg (8.47 lb)