

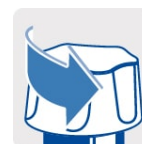

CÓDIGO: 49230 CLAVE: M-048

Mezcladora 4" para lavabo, nariz larga, cartucho cerámico

- Cuerpo y nariz de latón para máxima duración
- Manerales metálicos hexagonales
- Cubierta de acero inoxidable
- Cartucho cerámico de suave y fácil apertura



1/4 de vuelta

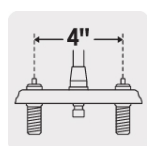

Distancia entre taladros



Cartucho cerámico 90°

Certificaciones y garantías

- Cumple la norma NMX-C-415-ONNCCE



Especificaciones

Acabado	Cromo
Distancia entre taladros	4"
Presión de trabajo	0.25 kgf/cm ² a 1 kgf/cm ²
Conexión roscable	1/2" - 14 NPSM
Dimensiones de la cubierta	7 cm x 15 cm x 5 cm
Peso	505 g
Empaque individual	Caja
Inner	2
Master	24
Pallet	288

Datos de Empaque (Medidas y pesos aproximados)

Empaque Individual	Medidas: Alto: 15.1 cm (6") Ancho: 9 cm (3 1/2") Largo: 16.4 cm (6 1/2") Peso: 0.5 kg (1.1 lb)
Inner	Medidas: Alto: 19.6 cm (7 1/2") Ancho: 16 cm (6 1/2") Largo: 17.3 cm (7") Peso: 1.2 kg (2.65 lb)
Master	Medidas: Alto: 42 cm (16 1/2") Ancho: 34.2 cm (13 1/2") Largo: 54 cm (21 1/4") Peso: 16.1 kg (35.49 lb)

País de origen

Fabricado en China bajo las estrictas especificaciones de GRUPO TRUPER

Imagenes complementarias



Altura (h)	Presión		
	kPa	kgf/cm ²	PSI
2.5 m	25	0.25	3.6
3 m	30	0.3	4.2
4 m	40	0.4	5.6

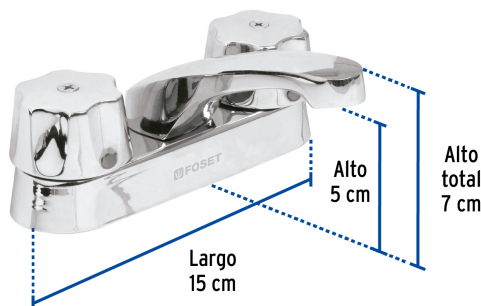
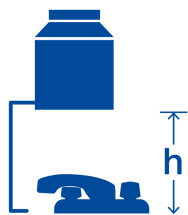

Imagenes complementarias

EMPAQUE INDIVIDUAL



Peso: 0.5 kg (1.1 lb)

EMPAQUE INNER

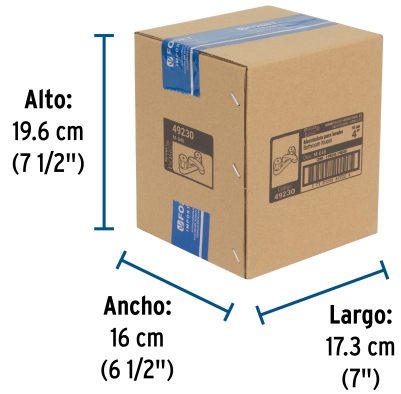

Contiene: 2 piezas

Peso: 1.2 kg (2.65 lb)

EMPAQUE MASTER



Contiene: 12 inner (24 piezas)

Peso: 16.1 kg (35.49 lb)

