

PRETUL®



CÓDIGO: 21455 CLAVE: VER-6PX

Vernier de 6", Pretul

- Cuerpo de acero
- Para medir diámetros externos, internos y profundidades



Diámetro externo

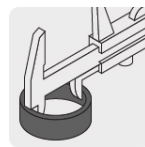

Diámetro interno

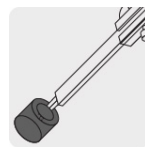

Profundidad

Certificaciones y garantías



Especificaciones

Vernier	Escolar
Tolerancia	0.158" / 0.4 mm
Capacidad máxima	6" / 150 mm
Dimensiones (largo x ancho)	22.2 x 1.56 cm
Peso	85 g
Empaque individual	Blíster
Inner	6
Master	72
Pallet	2304

País de origen

Fabricado en China bajo las estrictas especificaciones de Truper

Imágenes complementarias

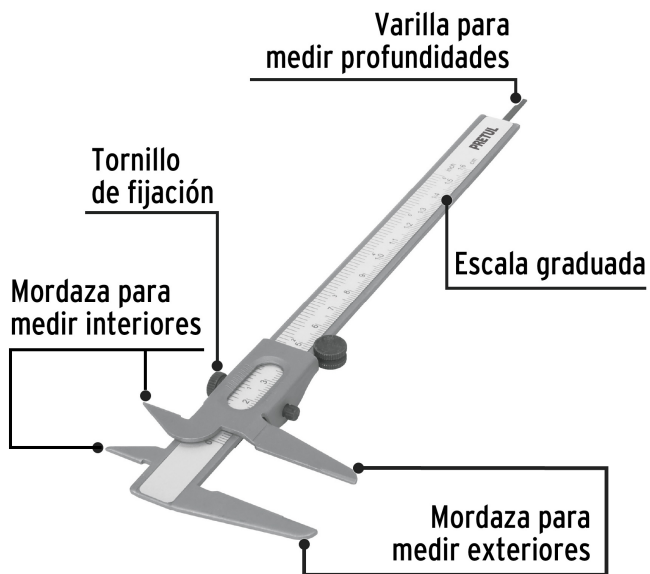

- A: Largo total 22.2 cm
- B: Ancho 15.6 mm
- C: Alto de la mordaza interior 12.4 mm
- D: Alto de la mordaza exterior 31 mm

