

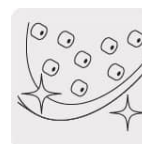

CÓDIGO: 45784 CLAVE: R-312SN

Regadera satín 12" plato cuadrado delgado sin brazo, Foset

- Cabeza de acero inoxidable
- Para mayor flujo de agua se puede retirar el reductor
- Compatible con el brazo y chapetón BCH-710N marca Foset ®

Boquillas fácil
limpieza

Articulada

Certificaciones y garantías

- Cumple la norma NOM-008-CONAGUA



Especificaciones

Diámetro de la cabeza	12" (30 cm)
Acabado	Satín
Presión de trabajo	1 kgf/cm ² a 6 kgf/cm ²
Consumo mínimo máximo	4 l/min 10 l/min
Conexión de entrada	1/2" - 14 NPT
Empaque individual	Caja
Inner	1
Master	4
Pallet	108

País de origen

Fabricado en China bajo las estrictas especificaciones de GRUPO TRUPER

Imagenes complementarias

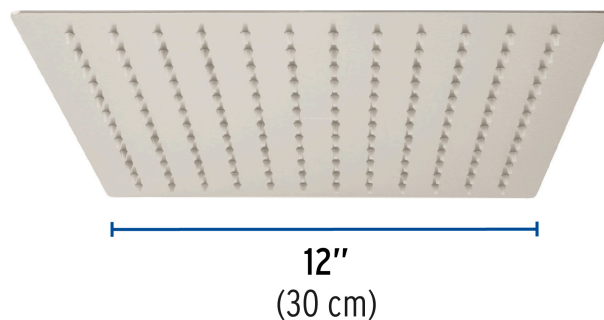
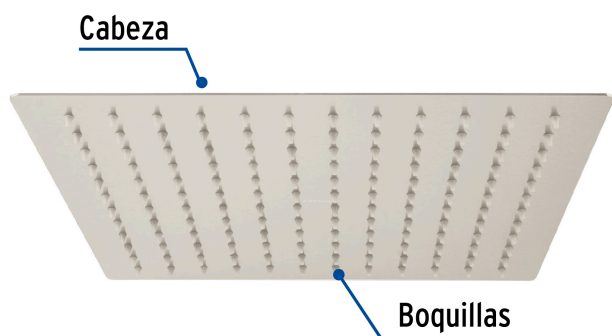

Para mayor flujo de agua se puede retirar el reductor

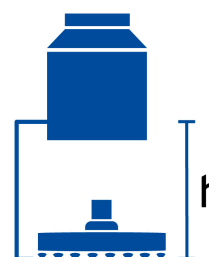
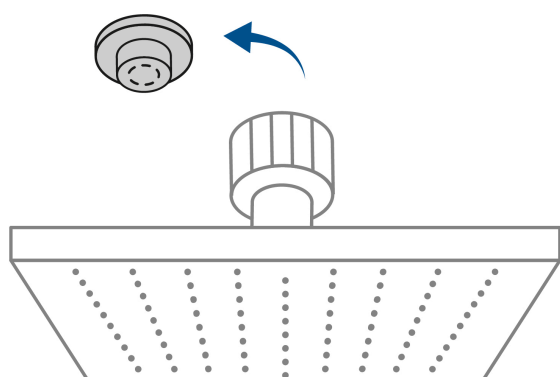

Altura (h)	Presión		
	kPa	kgf / cm ²	PSI
2 m	20	0.2	2.8
3 m	30	0.3	4.2
4 m	40	0.4	5.6

Imágenes complementarias

Compatible con el brazo y chapetón para regadera, 50 cm, satinado



BCH-750N

