

VOLTECK.



CÓDIGO: 47350 CLAVE: COSO-DA-2

Contacto de sobreponer dúplex 2 polos+ tierra, ABS, Volteck

- Fabricado en ABS
- Con retardante a la flama para mayor seguridad
- 2 Polos + tierra



Certificaciones y garantías

- Cumple la norma: NOM-003-SCFI



Especificaciones

Color	Marfil
Tensión / Frecuencia	127 V / 60 Hz
Corriente	15 A
Dimensiones (largo x ancho)	96.8 mm x 69.1 mm
Empaque individual	Bolsa
Inner	10
Master	100
Pallet	5000

Datos de Empaque (Medidas y pesos aproximados)

Empaque Individual	Medidas: Alto: 20.5 cm (8") Ancho: 2.5 cm (1") Largo: 10.9 cm (4 1/4") Peso: 0.06 kg (0.13 lb)
Inner	Medidas: Alto: 8.1 cm (3 1/4") Ancho: 14 cm (5 1/2") Largo: 20.8 cm (8 1/4") Peso: 0.68 kg (1.50 lb)

Datos de Empaque (Medidas y pesos aproximados)**Master****Medidas:** Alto: 23 cm (9") Ancho: 30 cm (11 3/4") Largo: 42.2 cm (16 1/2") **Peso:** 7.11 kg (15.67 lb)**País de origen****Fabricado en China bajo las estrictas especificaciones de Truper****Incluye**

Tapa trasera

Imágenes complementarias

Imágenes complementarias

Diagrama de conexión

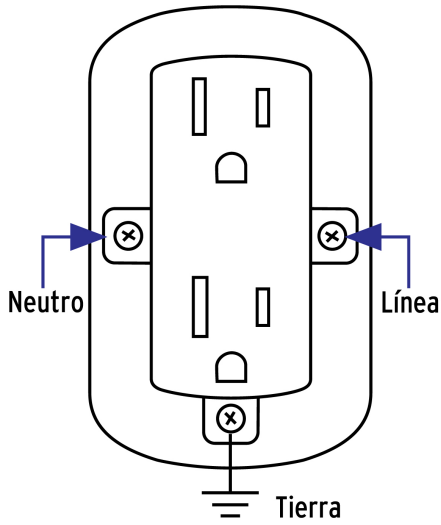

EMPAQUE INDIVIDUAL



Peso: 0.06 kg (0.13 lb)

EMPAQUE INNER



Contiene: 10 piezas

Peso: 0.68 kg (1.50 lb)

Imágenes complementarias

EMPAQUE MASTER

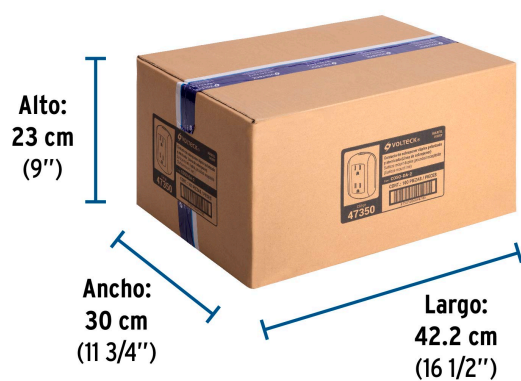

Contiene: 10 inner (100 piezas)

Peso: 7.11 kg (15.67 lb)