

VOLTECK.



CÓDIGO: 46103 CLAVE: COSO-DA

Contacto de sobreponer dúplex, 2 polos+ tierra, baquelita

- Fabricado en baquelita
- Con retardante a la flama para mayor seguridad
- 2 Polos + tierra



Certificaciones y garantías

- Cumple la norma: NOM-003-SCFI



Especificaciones

Color	Marfil
Tensión / Frecuencia	127 V / 60 Hz
Corriente	15 A
Dimensiones (largo x ancho)	92 mm x 48 mm
Peso	93.0 g
Empaque individual	Bolsa
Inner	10
Master	100
Pallet	4800

Datos de Empaque (Medidas y pesos aproximados)

Empaque Individual	Medidas: Alto: 20 cm (7 3/4") Ancho: 2.7 cm (1") Largo: 11 cm (4 1/4") Peso: 0.09 kg (0.20 lb)
Inner	Medidas: Alto: 11 cm (4 1/4") Ancho: 12.8 cm (5") Largo: 15.4 cm (6") Peso: 0.98 kg (2.16 lb)

Datos de Empaque (Medidas y pesos aproximados)**Master****Medidas:** Alto: 27.3 cm (10 3/4") Ancho: 16.2 cm (6 1/4") Largo: 57 cm (22 1/2") **Peso:** 10.14 kg (22.35 lb)**País de origen****Fabricado en China bajo las estrictas especificaciones de GRUPO TRUPER****Incluye**

Tapa trasera

Imágenes complementarias

Fabricado en baquelita



Imagenes complementarias

Diagrama de conexión

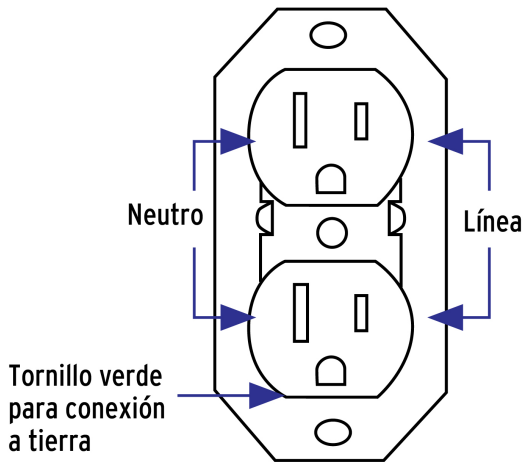

EMPAQUE INDIVIDUAL

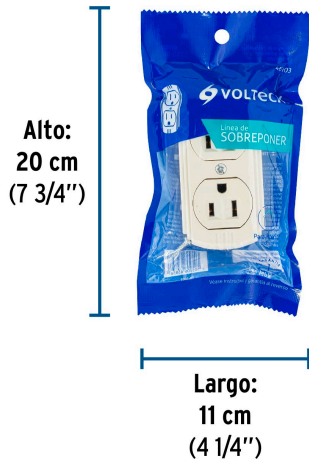

Peso: 0.09 kg (0.20 lb)

EMPAQUE INNER



Contiene: 10 piezas

Peso: 0.98 kg (2.16 lb)

Imágenes complementarias

EMPAQUE MASTER



Contiene: 10 inner (100 piezas)

Peso: 10.14 kg (22.35 lb)