



CÓDIGO: 46406 CLAVE: PPDO-S

Placa de ABS dúplex, Standard, marfil

- Fabricada en ABS
- Con 2 módulos para contactos y/o interruptores



Certificaciones y garantías



Especificaciones

Tipo de placa	Dúplex
Color	Marfil
Número de módulos	2
Dimensiones del módulo	34.1 mm x 28.5 mm
Dimensiones de la placa	114.0 mm x 69.6 mm
Empaque individual	Bolsa
Inner	20
Master	400
Pallet	10800

Datos de Empaque (Medidas y pesos aproximados)

Master	Medidas: Alto: 30.5 cm (12") Ancho: 38 cm (15") Largo: 37 cm (14 1/2") Peso: 7.86 kg (17.33 lb)
Inner	Medidas: Alto: 14 cm (5 1/2") Ancho: 7.2 cm (2 3/4") Largo: 18 cm (7") Peso: 0.36 kg (0.79 lb)

Datos de Empaque (Medidas y pesos aproximados)

Empaque Individual **Medidas:** Alto: 17.5 cm (7") Ancho: 0.8 cm (1/4") Largo: 8.6 cm (3 1/2") **Peso:** 0.01 kg (0.02 lb)

País de origen

Fabricado en México bajo las estrictas especificaciones de GRUPO TRUPER

Imágenes complementarias

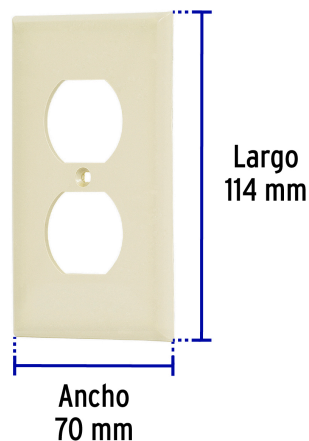

EMPAQUE INDIVIDUAL



Largo:
8.6 cm
(3 1/2")

Peso: 0.01 kg (0.02 lb)

Imagenes complementarias**EMPAQUE INNER**

Contiene: 20 piezas

Peso: 0.36 kg (0.79 lb)

EMPAQUE MASTER

Contiene: 20 inner (400 piezas)

Peso: 7.86 kg (17.33 lb)