



CÓDIGO: 46100 CLAVE: CODO-MS

Contacto dúplex, 2 polos 3 hilos, 20 A, Standard, marfil

- Fabricado en nylon-policarbonato
- Alta tensión
- Con retardante a la flama para mayor seguridad



Certificaciones y garantías

- Cumple la norma: NOM-003-SCFI



Especificaciones

Color	Marfil
Tensión	127 V
Corriente	20 A
Empaque individual	Bolsa
Inner	10
Master	100
Pallet	4500

Datos de Empaque (Medidas y pesos aproximados)

Empaque Individual	Medidas: Alto: 18.5 cm (7 1/4") Ancho: 2.8 cm (1") Largo: 8.2 cm (3 1/4") Peso: 0.07 kg (0.15 lb)
Inner	Medidas: Alto: 7.2 cm (2 3/4") Ancho: 14 cm (5 1/2") Largo: 21.2 cm (8 1/4") Peso: 0.81 kg (1.79 lb)
Master	Medidas: Alto: 30.5 cm (12") Ancho: 23 cm (9") Largo: 37.8 cm (14 3/4") Peso: 8.54 kg (18.83 lb)

País de origen

Fabricado en China bajo las estrictas especificaciones de GRUPO TRUPER

Fabricado en China bajo las estrictas especificaciones de GRUPO TRUPER

Imagenes complementarias

Fabricado en nylon-policarbonato

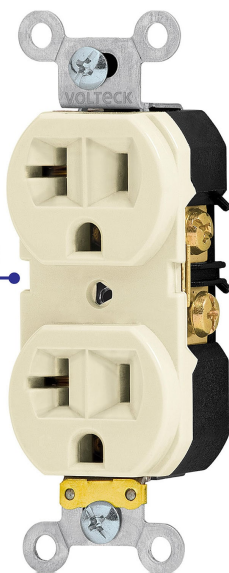

Largo 83.3 mm



Diagrama de conexión



Imagenes complementarias**EMPAQUE INDIVIDUAL**

Peso: 0.07 kg (0.15 lb)

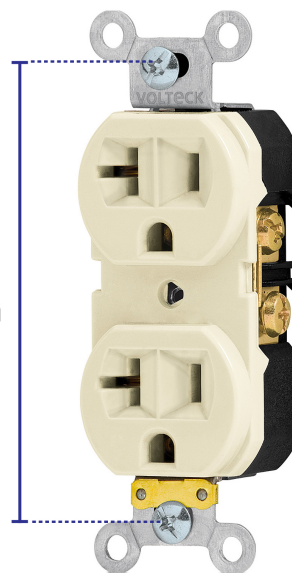
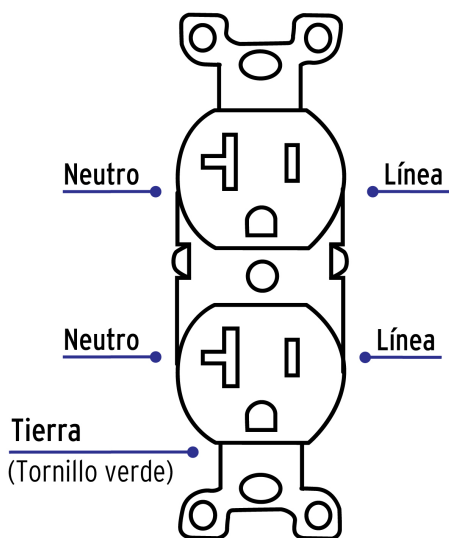
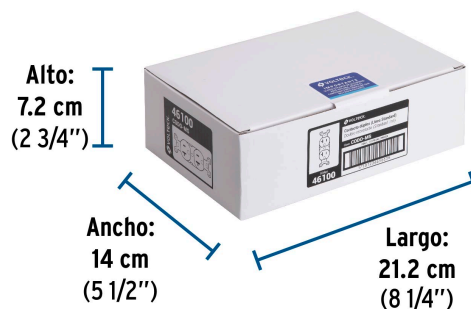
EMPAQUE INNER

Contiene: 10 piezas

Peso: 0.81 kg (1.79 lb)

EMPAQUE MASTER

Contiene: 10 inner (100 piezas)

Peso: 8.54 kg (18.83 lb)