



CÓDIGO: 46001 CLAVE: COAP-S

Interruptor de palanca con contacto, Standard, marfil

- Fabricado en nylon-policarbonato con soporte de acero galvanizado
- Con retardante a la flama para mayor seguridad



Certificaciones y garantías

- Cumple la norma: NOM-003-SCFI



Especificaciones

Color	Marfil
Interruptor (Tensión Corriente)	120 V 15 A
Contacto (Tensión Corriente)	127 V 15 A
Empaque individual	Bolsa
Inner	10
Master	100
Pallet	6000

Datos de Empaque (Medidas y pesos aproximados)

Empaque Individual	Medidas: Alto: 18.5 cm (7 1/4") Ancho: 4.1 cm (1 1/2") Largo: 8.8 cm (3 1/2") Peso: 0.06 kg (0.13 lb)
Inner	Medidas: Alto: 7.5 cm (3") Ancho: 14 cm (5 1/2") Largo: 21.2 cm (8 1/4") Peso: 0.64 kg (1.41 lb)
Master	Medidas: Alto: 29.5 cm (11 1/2") Ancho: 22.7 cm (9") Largo: 40 cm (15 3/4") Peso: 6.96 kg (15.34 lb)

País de origen

Fabricado en China bajo las estrictas especificaciones de GRUPO TRUPER

Incluye

Tornillería

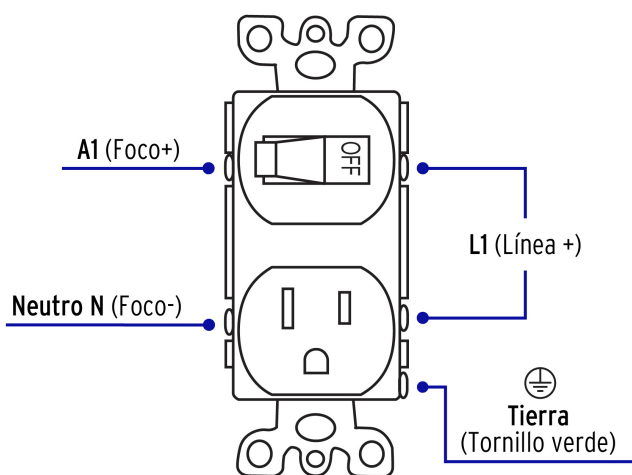
Imágenes complementarias**Diagrama de conexión**

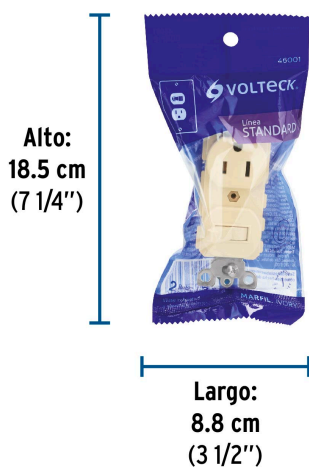
Imagenes complementarias**EMPAQUE INDIVIDUAL**

Peso: 0.06 kg (0.13 lb)

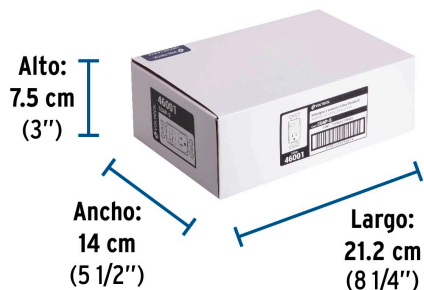
EMPAQUE INNER

Contiene: 10 piezas

Peso: 0.64 kg (1.41 lb)

EMPAQUE MASTER

Contiene: 10 inner (100 piezas)

Peso: 6.96 kg (15.34 lb)